

## MotionPak® II

### Applications

- Vehicle Instrumentation
- Robotics
- Remotely Piloted Vehicles
- Attitude Reference Systems
- Industrial Control Systems
- Navigation Aiding GPS
- Marine Instrumentation
- Flight Testing



### Description

The MotionPak® II is a “solid-state” MEMS six degree of freedom inertial sensing system used for measuring linear accelerations and angular rates in instrumentation and control applications. It is a highly reliable, compact, and rugged package providing both analog and digital (RS-232) outputs. With three orthogonally mounted micromachined quartz angular rate sensors and three silicon based accelerometers, the MotionPak II is a fully self-contained motion measurement package utilizing internal power regulation and signal conditioning electronics.

### Key Performance Features

- “Solid-State” Sensors
- Dual Level Analog Outputs
- RS-232 Digital Output
- Single Supply Feature
- Compact, Rugged Package
- Wide Bandwidth
- Long Operating Life
- Fast Start-Up
- Low Cost
- Fully Self-Contained System



[www.systron.com](http://www.systron.com)

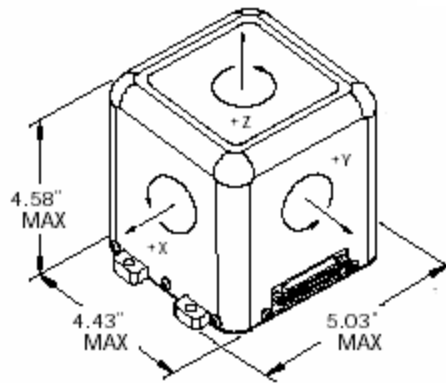

<b>Part Number:</b>	<b>MP2K-CCC-666-100</b>			
	<b>STANDARD OUTPUTS</b>		<b>SINGLE SUPPLY FEATURE</b>	
	(High, low & RS-232 outputs)		(Low Output & RS-232 only)	
Input Power	Dual Supply (bipolar)		Single supply	
Input Voltage	+ and - 15 Vdc ±1 Vdc		+ 11.0 Vdc +16.0 Vdc	
Input Current	Plus Supply <125 milliampere		<125 milliampere	
	Minus Supply <35 milliampere			
<b>Performance</b>	<b>Rate Channels</b>	<b>Accelerometer Channels</b>	<b>Rate Channels</b>	<b>Accelerometer Channels</b>
Standard ranges	±75°/sec	±1.5g	±75°/sec	±1.5g
Full Scale HIGH Analog Output	±10 Vdc	±10 Vdc	--	--
Full Scale LOW Analog Output	+0.5/+4.5 Vdc	+0.5/+4.5 Vdc	+0.5/+4.5 Vdc	+0.5/+4.5 Vdc
Scale Factor HIGH-nominal	0.133 V/°/sec	6.66 V/g	--	--
Scale Factor LOW-nominal	0.027 V/°/sec	1.2 V/g	0.027 V/°/sec	1.2 V/g
Sensitivity (Error) -40 to +85°C	±6% (1)	±5%	±6% (1)	±5%
Offset HIGH-nominal	0 Vdc	0 Vdc	--	--
Offset low-NOMINAL	2.5 Vdc	2.5 Vdc	2.5 Vdc	2.5 Vdc
Offset (-40 to +85°C)	±5.0°/sec (2)	±125 mg	±5.0°/sec	±125 mg
Output noise High Analog	28 mV RMS	28 mV RMS	--	--
Output noise Low Analog	6 mV RMS	5 mV RMS	6 mV RMS	5 mV RMS
Start-up time	1.0 Second	1.0 Second	1.0 Second	1.0 Second
Bandwidth	DC to >30 Hz	DC to >250 Hz	DC to >30 Hz	DC to > 250 Hz
Non-linearity (% Full Range)	<3%	±40 mg	<3%	±40 mg
<b>Environments</b>				
Operating temperature	-40 TO +85°C		-40 TO +85°C	
Storage temperature	-40 TO +85°C		-40 TO +85°C	
Vibration survival	4 g RMS (20 – 2 KHz)		4 g RMS (20 – 2 KHz)	
Shock	200 g PK 2 mSec ½ sine pulse		200 g PK 2 mSec ½ sine pulse	
(1) Sum of 3% Set and 3% Linearity, worst case				
(2) Sum of 1.8°/sec Set and 3.2°/sec TC, worst case				
RS-232 Feature				
	Data Transfer Rate: 32 Hz maximum (measuring 7 "12 BIT" WORDS)			
	LSB = 1.2 millivolt (Least Significant BIT)			
<b>Temperature Sensor</b>				
	10 millivolt/°K	-40°C (233.15°K) = +2.33 Vdc	+85°C (358.15°K) = +3.58 Vdc	

**For more information contact:**

Systron Donner Inertial  
 2700 Systron Drive  
 Concord, California 94518 USA  
 +1-925-979-4500 or +1-866-234-4976



Email: [Sales@sys tron.com](mailto:Sales@sys tron.com)